

DESIGNED FOR USE WITH RG-55/U, 142, 223, & 400 CABLES	
CABLE ENTRY DIAMETER MINIMUM	
FERRULE	.219
SLEEVE	.122
CONTACT	.042

REVISIONS			
REV	DESCRIPTION	DATE	APPROVED
02 ₁	REVISED	7/15/96	<i>PCW</i> 7/16/96
B	PER EC 0U20-0692-00	9/25/01	<i>C. Huang</i> 9/25/01

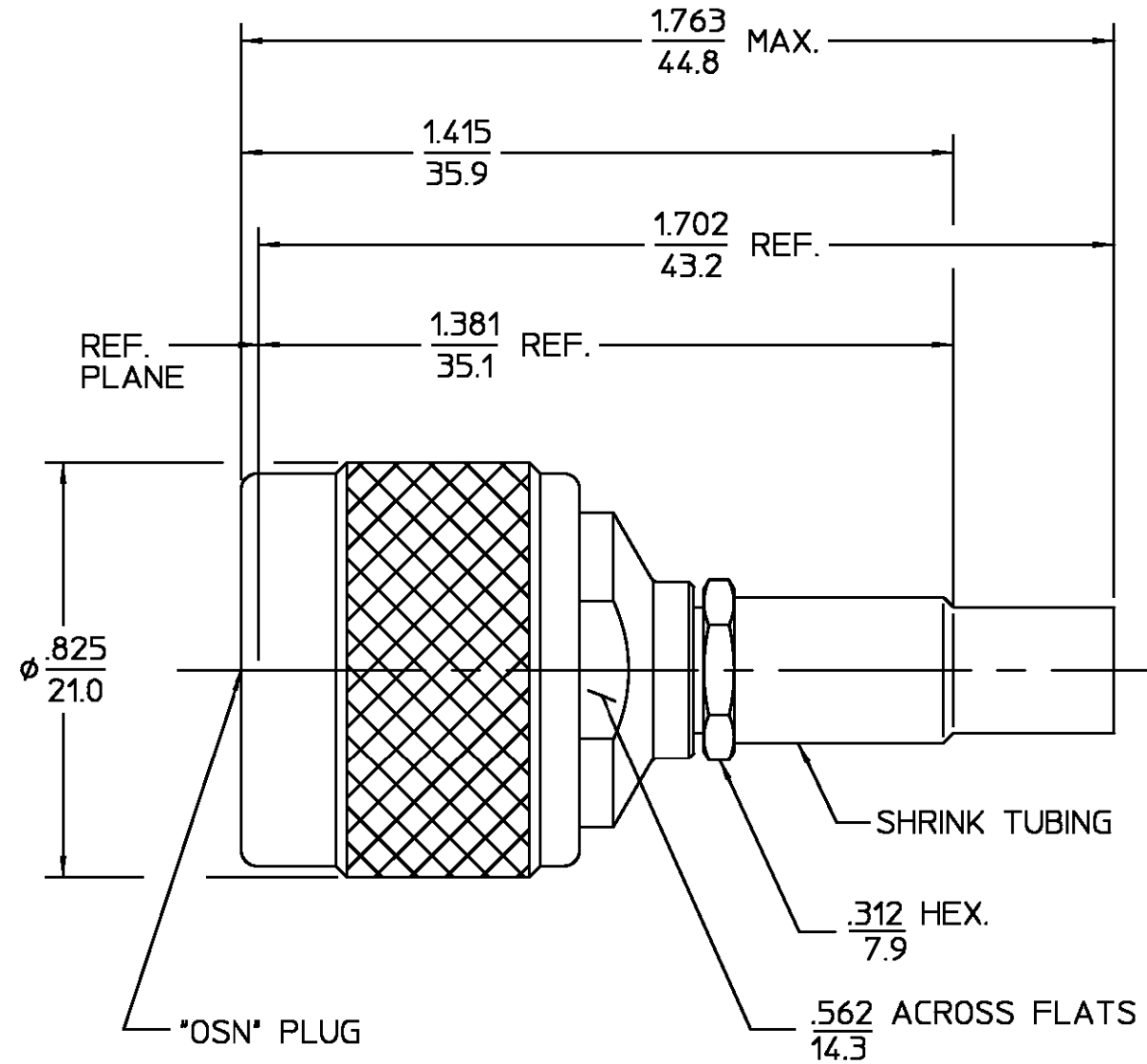

HOUSING	BRASS PER ASTM-B-16, HALF HARD	NICKEL PLATE PER QQ-P-35
CLAMP NUT		
COUPLING NUT		
DIELECTRIC	TFE FLUOROCARBON PER ASTM-D-1457	N/A
CENTER CONTACT	BRASS PER ASTM-B-16, HALF HARD	GOLD PLATE PER MIL-G-45204
RETAINING RING	PHOSPHOR BRONZE PER QQ-B-750, GRADE B2	N/A
GASKET	SILICONE RUBBER PER ZZ-R-765	N/A
SLEEVE	BRASS PER ASTM-B-16, HALF HARD	GOLD PLATE PER MIL-G-45204
SHRINK TUBING	HEAT SHRINKABLE POLYOLEFIN COMPOUND MIL-I-23053/4	N/A
FERRULE	COPPER OR BRASS ALLOY ROCKWELL F65 MAXIMUM	GOLD PLATE PER MIL-G-45204

COMPONENT	MATERIAL	FINISH
-----------	----------	--------

UNLESS OTHERWISE SPECIFIED DIMENSIONS ARE IN INCHES	DRAWN BY	DATE	AMP Incorporated 140 Fourth Avenue Waltham, MA 02451-7599	
	T.M.	11/15/82		
	CHECKED BY	R.G.		11/15/82
FRAC. ± 1/64	DEC. ± .005	ANGLES ± 1°	APPD BY R.M.F.	11/16/82

These drawings and specifications are the property of M/A COM Interconnect Div. and shall not be reproduced or copied or used in whole or in part as the basis for the manufacture or sale of item(s) without written permission.	USE ASSY PROCEDURE	TITLE "OSN" STRAIGHT CABLE PLUG CRIMP ATTACHMENT	
	NO. AP. 408-04892 (30-051)	SIZE B	CODE IDENT NO. 26805
		SCALE 3:1	3031-7341-10
			SHEET 1 OF 1

NOTES:
1. CAPTURED CENTER CONTACT

.XXX = in
XX.X = mm (REF)